



INSTALLATION INSTRUCTIONS

ISD 4-CHANNEL INTRINSICALLY SAFE RELAYS

September 2018

901-0000-328

DANGER!



Potentially hazardous voltages are present. Electrical shock can cause death or serious injury. Installation should be done by qualified personnel following all National, State & Local Codes.



Présence de tensions potentiellement dangereuses. Une décharge électrique peut causer la mort ou des blessures graves. L'installation devrait être effectuée par du personnel qualifié suivant tous les codes nationaux, provinciaux et locaux.

BE SURE TO REMOVE ALL POWER SUPPLYING THIS EQUIPMENT BEFORE CONNECTING OR DISCONNECTING WIRING. READ INSTRUCTIONS BEFORE INSTALLING OR OPERATING THIS DEVICE. KEEP FOR FUTURE REFERENCE.

S'ASSURER DE SUPPRIMER TOUTE ALIMENTATION ÉLECTRIQUE DE CET ÉQUIPEMENT AVANT DE BRANCHER OU DE DÉBRANCHER LES CÂBLAGES. LIRE LES INSTRUCTIONS AVANT D'INSTALLER OU D'UTILISER CET APPAREIL ET LES CONSERVER POUR RÉFÉRENCE ULTÉRIEURE.

Installation & Wiring

- The ISD Series Intrinsicly Safe relays are UL913 Listed as associated apparatus for interfacing between hazardous and safe areas. The ISD relay must be installed in a suitable enclosure in a safe area.
- For DIN-rail mounting, snap the relay on 35mm DIN track. For panel mounting, first remove both terminal connectors from the safe and hazardous sides. Then, using a thumb, gently extend the two black DIN-rail clips from under the relay until they snap into place and the mounting hole on each one is visible. Mount the relay to the panel using a #8 screw through the hole on each clip.
- Connect all wires to the device per Macromatic Control Drawing ISD1A04 (on back). The safe (black) and hazardous (blue) terminal connectors are removable for easier wiring and keyed to prevent incorrect wiring. Use #14-24 solid or stranded copper wire with a terminal tightening torque of 7 in-lb. If terminal connectors were removed, be sure to fully reinsert the terminal connectors into the proper color-coded receptacle on the device.

Operation

The ISD Series relay consists of four intrinsically safe inputs and corresponding electromechanical relay outputs for each. There are also nine LEDs for status indication as defined below.

Configuration	<i>The ISD series includes four configurations providing support for a wide variety of applications. Each configuration is user-selectable using a 2-position DIP switch easily accessible on the top of the product (see Diagram right). Factory switch settings will be Standard Logic (STD) and No Delay (0 S).</i>	DIP Switch Settings
Standard Logic, No Delay	With input voltage applied, the V LED will be ON (GREEN) to indicate power is applied. When an input device from the hazardous area is closed, the input LED is ON (GREEN); the corresponding output relay is energized and the output LED is ON (ORANGE). When the input device opens, the input LED will be OFF; the corresponding output relay will de-energize and the output LED will be OFF.	DELAY: 0 S 2 S LOGIC: STD INV
Inverse Logic, No Delay	With input voltage applied, the V LED will be ON (GREEN) to indicate power is applied. If an input device from the hazardous area is open when input voltage is applied, the input LED will be OFF, the corresponding output relay will be ON and the output LED will be ON (ORANGE). When an input device is closed, the input LED is ON (GREEN); the corresponding output relay will de-energize and the output LED will be OFF. When the input device opens, the input LED will be OFF; the corresponding output relay will energize and the output LED will be ON (ORANGE).	DELAY: 0 S 2 S LOGIC: STD INV
Standard Logic, 2 Second Delay	With input voltage applied, the V LED will be ON (GREEN) to indicate power is applied. When an input device from the hazardous area is closed, the input LED is ON (GREEN) and the corresponding output LED will FLASH (ORANGE) for 2 seconds. Then the corresponding output relay is energized and the output LED is ON (ORANGE). When the input device opens, the input LED will be OFF and the corresponding output LED will FLASH (ORANGE) for 2 seconds. Then the corresponding output relay will de-energize and the output LED will be OFF. If the input device changes state at any time during the delay, the corresponding output relay will remain in the current state, the output LED will stop FLASHING and the time delay will reset.	DELAY: 0 S 2 S LOGIC: STD INV
Inverse Logic, 2 Second Delay	With input voltage applied, the V LED will be ON (GREEN) to indicate power is applied. If an input device from the hazardous area is open when input voltage is applied, the input LED will be OFF, the corresponding output relay will be OFF, and the output LED will FLASH (ORANGE). After 2 seconds, the corresponding output relay will energize and the output LED will be ON (ORANGE). When the input device closes, the input LED is ON (GREEN) and the corresponding output LED will FLASH (ORANGE). After 2 seconds, the corresponding output relay will de-energize and the output LED will be OFF. When the input device opens, the input LED will be OFF and the corresponding output LED will FLASH (ORANGE). After 2 seconds, the corresponding output relay will energize and the output LED will be ON (ORANGE). If the input device changes state at any time during the delay, the corresponding output relay will remain in the current state, the output LED will stop FLASHING and the time delay will reset.	DELAY: 0 S 2 S LOGIC: STD INV

Troubleshooting: If the unit fails to operate properly, check that all connections are correct per Control Drawing ISD1A04. If the V LED flashes Red continuously, the device has been damaged and must be replaced.

Warranty: All catalog-listed ISD Series Intrinsicly Safe Relays manufactured by Macromatic are warranted to be free from defects in workmanship or material under normal service and use for a period of five (5) years from date of manufacture.

CONTROL DRAWING ISD1A04

ASSOCIATED APPARATUS / APPAREILLAGE CONNEXE

Revision A

Notes:

1. The output current of this associated apparatus is limited by a resistor such that the output voltage-current plot is a straight line drawn between open-circuit voltage and short-circuit current.

2. This associated apparatus may be connected to simple apparatus as defined in Article 504.2 installed and temperature classified in accordance with Article 504.10(D) of the National Electrical Code (ANSI/NFPA 70), or other local codes as applicable.

3. Capacitance and inductance of the field wiring from the simple apparatus to the associated apparatus shall be calculated. Cable capacitance, C_{cable} , must be less than the marked capacitance, C_a (or C_o), shown on the associated apparatus used. The same applies for inductance (L_{cable} , L_i and L_a or L_o , respectively). Where the cable capacitance and inductance per foot are not known, the following values shall be used: $C_{cable} = 60 \text{ pF/ft.}$, $L_{cable} = 0.2 \text{ }\mu\text{H/ft.}$

4. If connected to intrinsically safe equipment, the equipment must be third party listed as intrinsically safe for the application, and have intrinsically safe entry parameters conforming with the below.

I.S. Equipment	Associated Apparatus
V_{max} (or U_i)	$\geq V_{oc}$ (or U_o)
I_{max} (or I_i)	$\geq I_{sc}$ (or I_o)
P_{max} , P_i	$\geq P_o$
$C_i + C_{cable}$	$\geq C_a$ (or C_o)
$L_i + L_{cable}$	$\geq L_a$ (or L_o)

5. If connected to intrinsically safe equipment, capacitance and inductance of the field wiring from the intrinsically safe equipment to the associated apparatus shall be calculated and included in the system calculations as shown in Note 6.

6. Cable capacitance, C_{cable} , plus intrinsically safe equipment capacitance, C_i must be less than the marked capacitance, C_a (or C_o), shown on any associated apparatus used. The same applies for inductance (L_{cable} , L_a (or L_o), respectively). Where the cable capacitance and inductance per foot are not known, the following values shall be used: $C_{cable} = 60 \text{ pF/ft.}$, $L_{cable} = 0.2 \text{ }\mu\text{H/ft.}$

7. Associated apparatus must be installed in an enclosure suitable for the application in accordance with the National Electrical Code (ANSI/NFPA 70) for installation in the United States, the Canadian Electrical Code for installations in Canada, or other local codes, as applicable.

8. Intrinsically safe circuits must be wired and separated in accordance with Article 504.20 of the National Electrical Code (ANSI/NFPA 70) or other local codes, as applicable.

9. This associated apparatus has not been evaluated for use in combination with another associated apparatus.

10. If connected to intrinsically safe equipment, installations in which both the C_i and L_i of the intrinsically safe equipment exceed 1% of the C_a (or C_o) and L_a (or L_o) parameters of the associated apparatus (excluding the cable), then 50% of C_a (or C_o) and L_a (or L_o) parameters are applicable and shall not be exceeded. The reduced capacitance shall not be greater than 1 μF for Groups C and/or D, and 600 nF for Groups A and B. The values of C_a (or C_o) and L_a (or L_o) determined by this method shall not be exceeded by the sum of all of C_i plus cable capacitances and the sum of all of the L_i plus cable inductances.

11. All channels comprise a single intrinsically safe circuit.

Approvals:



Class I; Division I; Groups A,B,C,D
Class II; Division I; Groups E,F,G
Class III; Division I



Zone 0; [Ex ia] IIC Ga
Zone 20; [Ex ia] IIIC Da

Ratings:

- Input Voltage(V): 102-132VAC 10-125VDC
- Temperature(T_a): $-28^\circ\text{C} \leq T_a \leq 60^\circ\text{C}$ (Max. 3 A)
 $-28^\circ\text{C} \leq T_a \leq 40^\circ\text{C}$ (Max. 5 A)
- Maximum Voltage(U_m): 132VAC
- Contacts Ratings (terminals 3-4,5-6,7-8,9-10):
- 5A 125VAC/30VDC (Max. T_a 40°C)
- 3A 125VAC/30VDC (Max. T_a 60°C)
- D300 Pilot Duty (Max. T_a 60°C)

WARNING!

SUBSTITUTION OF COMPONENTS MAY IMPAIR INTRINSIC SAFETY.
AVERTISSEMENT!

LA SUBSTITUTION DE COMPOSANTS PEUT COMPROMETTRE LA SÉCURITÉ INTRINSÈQUE.

ISD, MBD SERIES

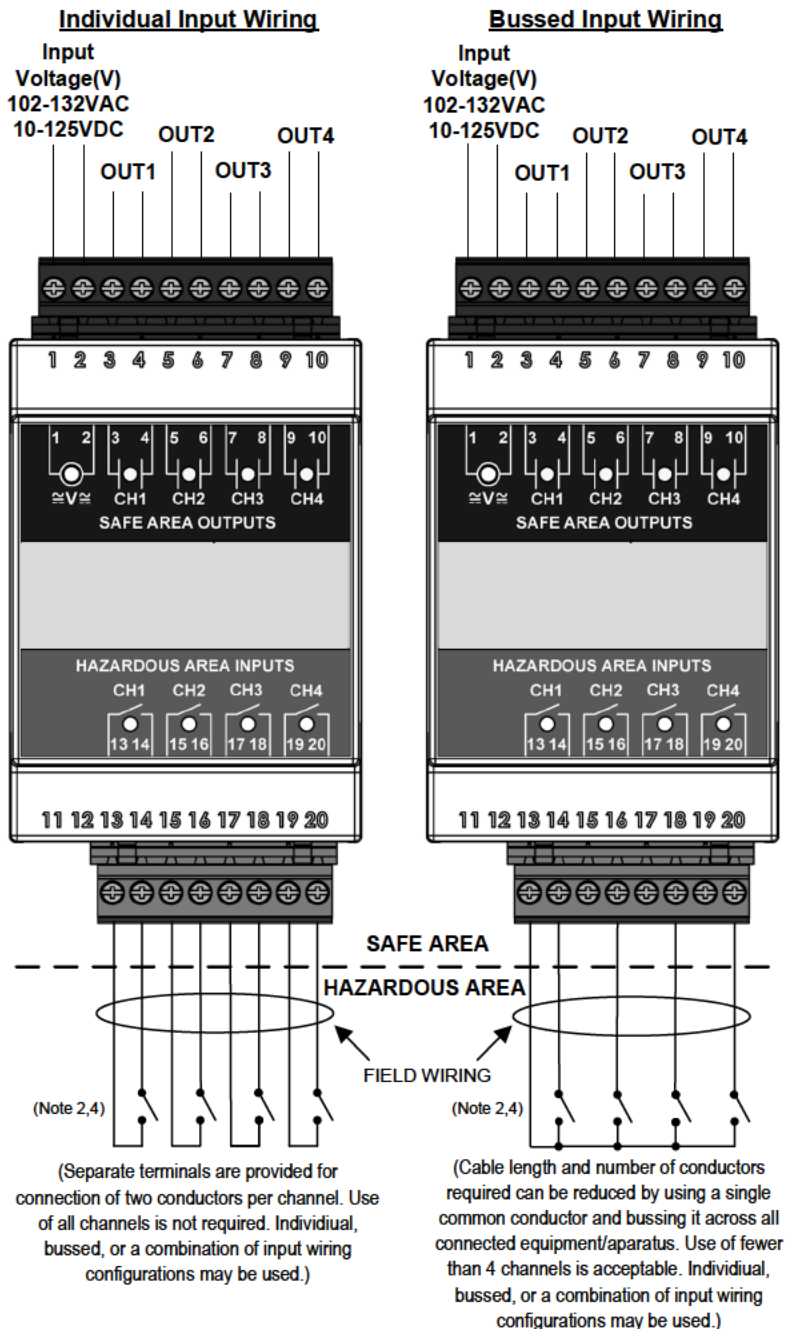

Entity Parameters

(terminals 13-14,15-16,17-18,19-20):

$V_{oc}(U_o)$	14.46 V
$I_{sc}(I_o)$	40.59 mA
P_o	146.74 mW
$C_a(C_o)$	0.65 μF
$L_a(L_o)$	21.58 mH